

Recommended Graphic Organizers Primary Grades K-3

Narrative

- Planning a Short Story (Step Up to Writing)
- Planning a Short Story with more in the middle (Step Up to Writing)
- Organizer for older students

Expository Writing

- T-charts (Step Up to Writing)
- T-Charts for older students
- Multiple Paragraph Plan

Summary Writing

- IVF (Step Up to Writing)

Response to Literature

- Planning Guide (Step Up to Writing)

Supplemental Resources

Thinking Maps

- Circle Map
- Bubble Map
- Double Bubble Map
- Tree Map
- Brace Map
- Flow Map
- Multi-Flow Map
- Bridge Map

Planning a Short Story



Title _____



Quick Sketch -
a plan for your story



Quick Notes - your ideas
and plans for your story

Beginning

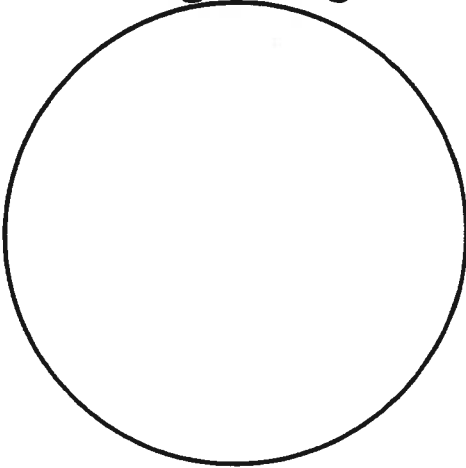

Middle

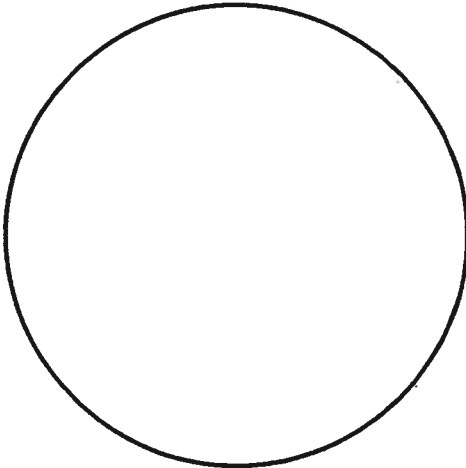

End

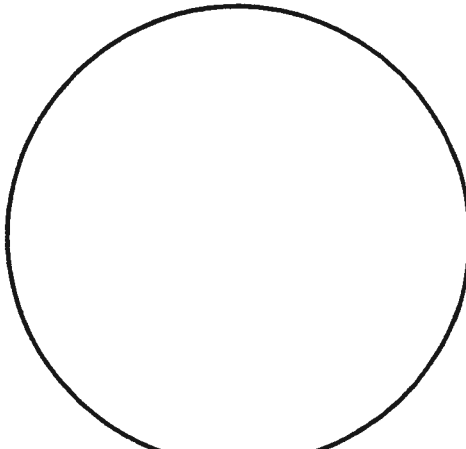

Handwriting practice lines for notes and plans. The page contains 21 horizontal lines, grouped into three sections of seven lines each, corresponding to the Beginning, Middle, and End stages of the story.

Name: _____ Date: _____

Planning a Short Story



Title _____



Quick Sketch
Plan your story.



Quick Notes
Jot down words that describe your story.

Beginning

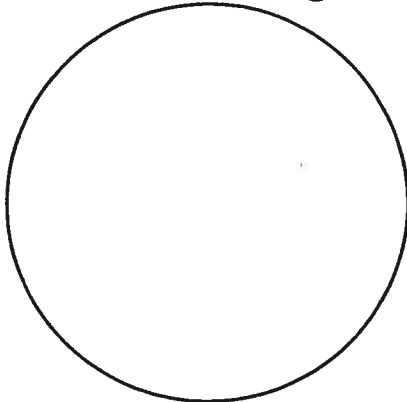

Middle

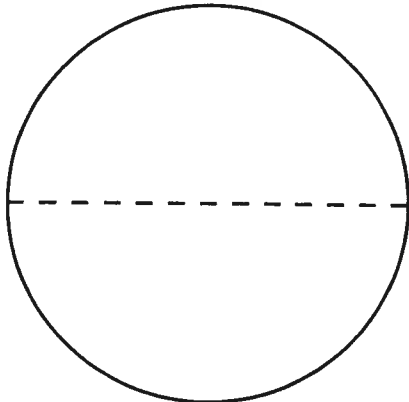

1

2

End

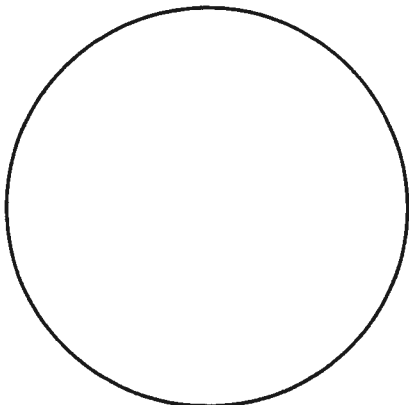

Narrative Graphic Organizer

Story Starter	
Beginning	Explain/Elaborate
Middle	Explain/Elaborate
End	Explain/Elaborate
Story Wrap-Up	

Name: _____ Date: _____

T =



C =

Planning for Information/ Expository Writing

Informal Outline

Title = _____

Topic = _____



—



—



—



—



Conclusion =

Expository Graphic Organizer

Topic Sentence	
Details	Explain/Elaborate
Details	Explain/Elaborate
Details	Explain/Elaborate
Conclusion	

Descriptive Graphic Organizer

Topic Sentence	
Fact	Explain/Elaborate - -
Fact	Explain/Elaborate - -
Fact	Explain/Elaborate - -
Fact	Explain/Elaborate - -
Conclusion	

Paragraph by Paragraph

Planning Guide for a Multiparagraph Paper

(Copy on green paper. Cut apart.)

Introduction	Title _____		
	Topic Sentence _____		

	Plan _____		

Block Out	☆ _____	☆ _____	Conclusion
Introduction			



Conclusion	Jot down three ideas to help you plan a conclusion.

Hint	<ul style="list-style-type: none">• Use synonyms.• Remind the reader of the topic.• Your conclusion will have at least two sentences.

(continued)

Paragraph by Paragraph *(continued)*

Planning Guide for a Multiparagraph Paper

(Copy on yellow paper. Cut apart. Write examples/explanations in red.)

OR Copy on pink paper. Cut apart. Highlight transition topic sentences in yellow.)

Body Paragraph	★ ()	_____
	—	_____
	•	_____
	•	_____
	—	_____
	•	_____



Body Paragraph	★ ()	_____
	—	_____
	•	_____
	•	_____
	—	_____
	•	_____

Name: _____ Date: _____

Writing Summaries

STEP 1

Write a three-part summary topic sentence.

Identify the Item.

Select a Verb.

Finish Your Thought with the Main Idea.

_____	_____	_____
_____		_____
_____		_____
_____		_____
_____		_____

STEP 2

Copy the sentence so it looks like a real sentence.

STEP 3

Write the facts.

STEP 4

Write the summary.

Name: _____ Date: _____

Response to Literature: Planning Guide

Topic Sentence _____ _____	
Proof from Text	Specific Examples with Details
★	
★	
★	
★	
Conclusion _____ _____	

DEFINING IN CONTEXT

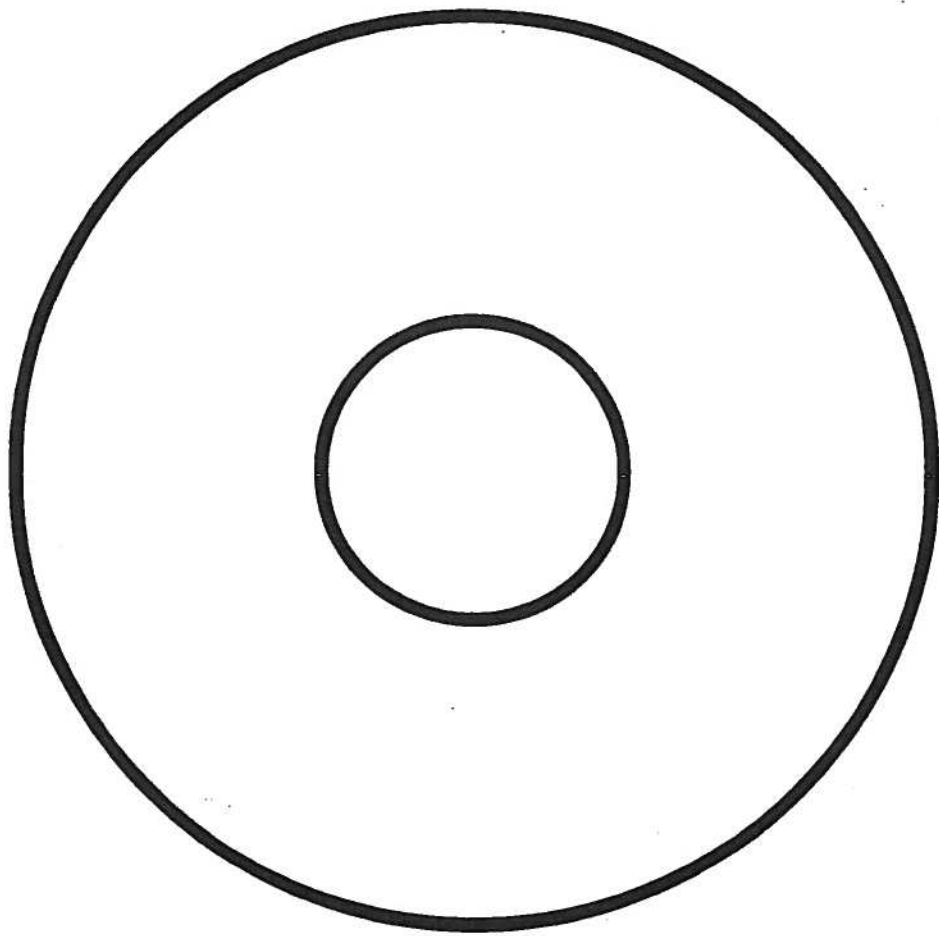

DESCRIBING

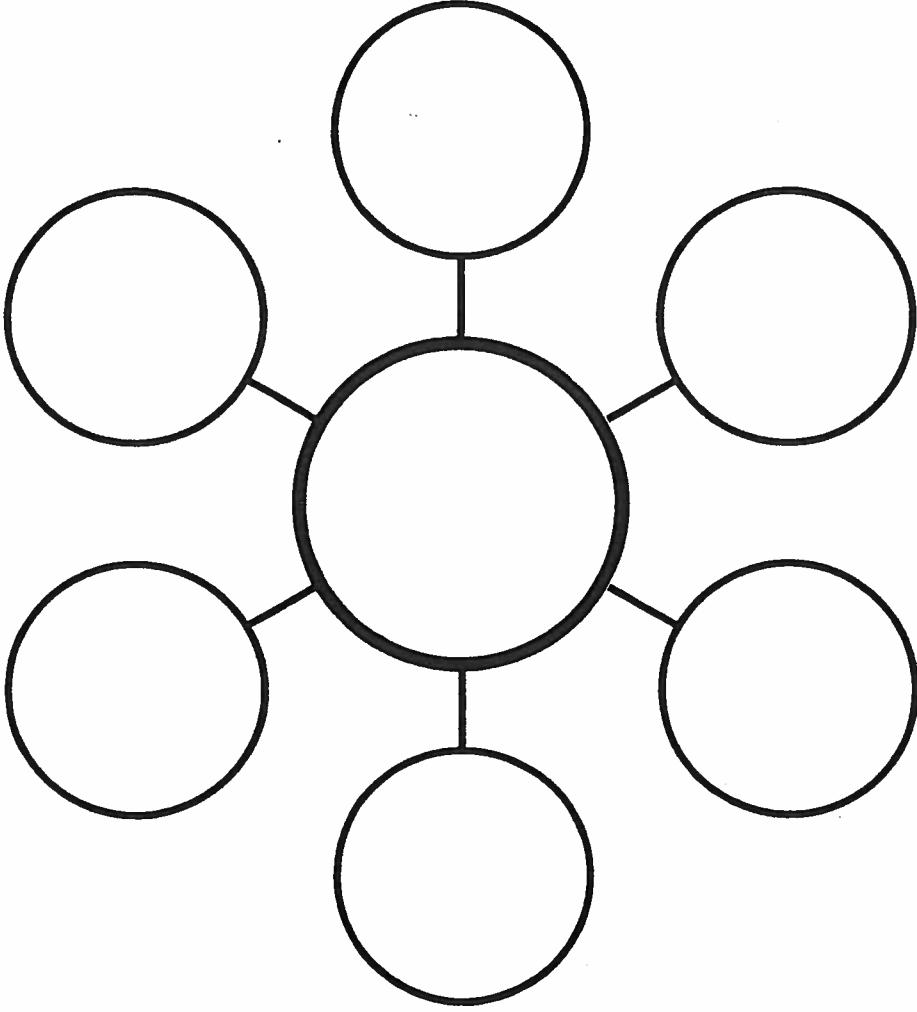

Bubble Map

COMPARING & CONTRASTING

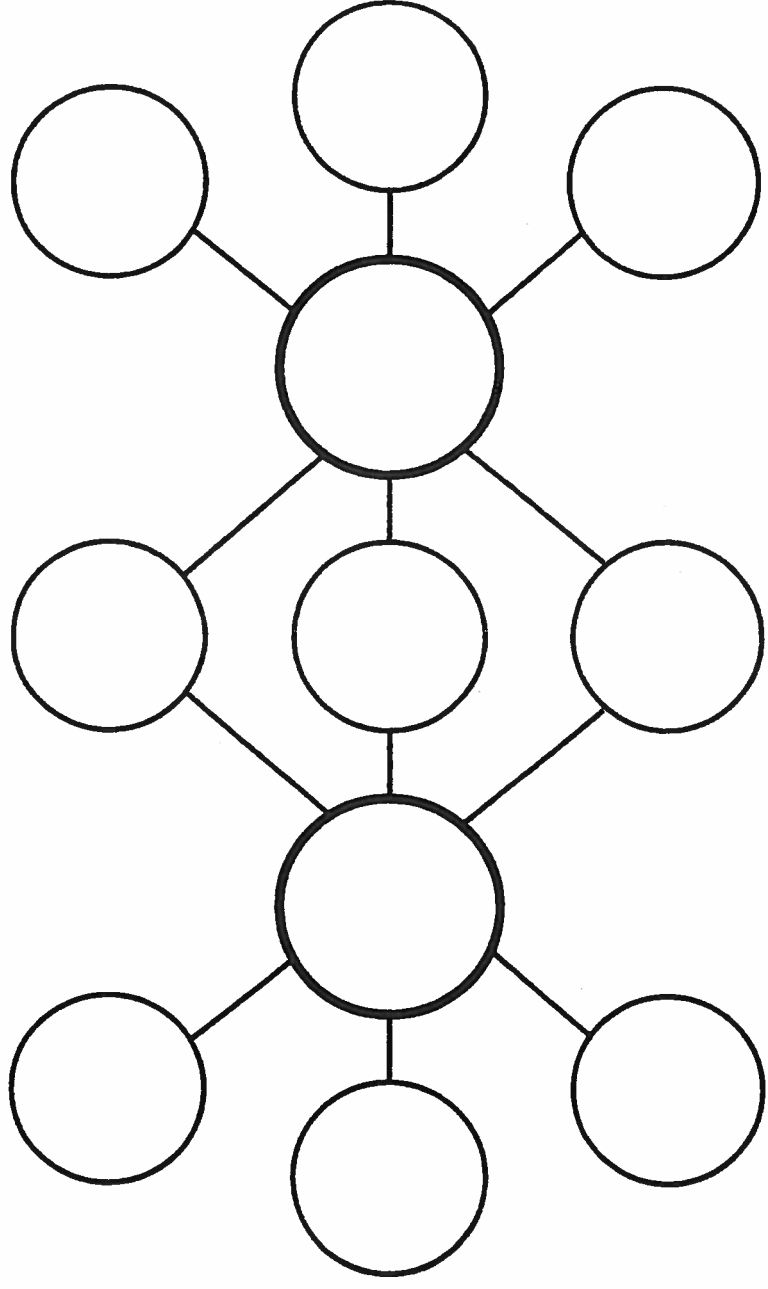

© 2007 Thinking Maps, Inc.

Double Bubble Map



CLASSIFYING

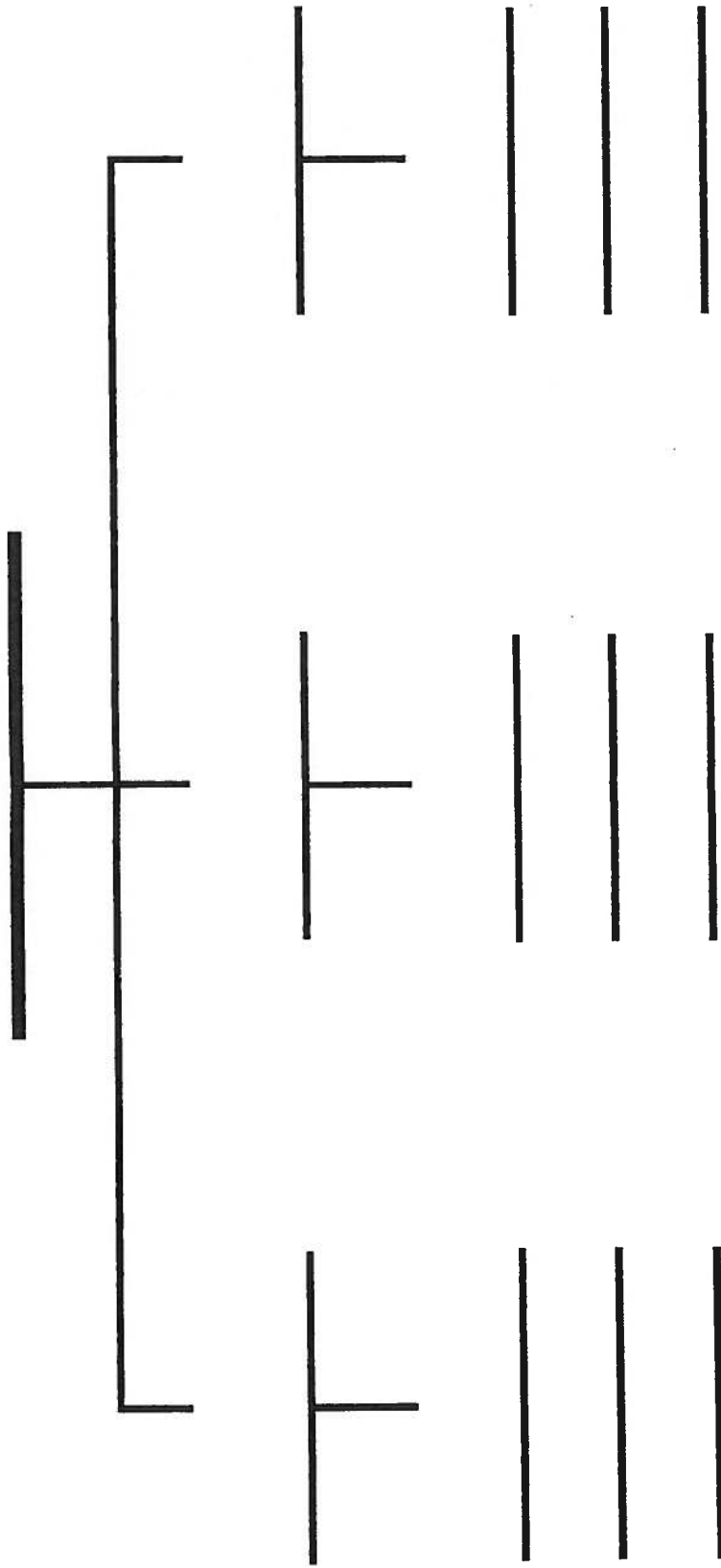

Tree Map

WHOLE - PART RELATIONSHIP

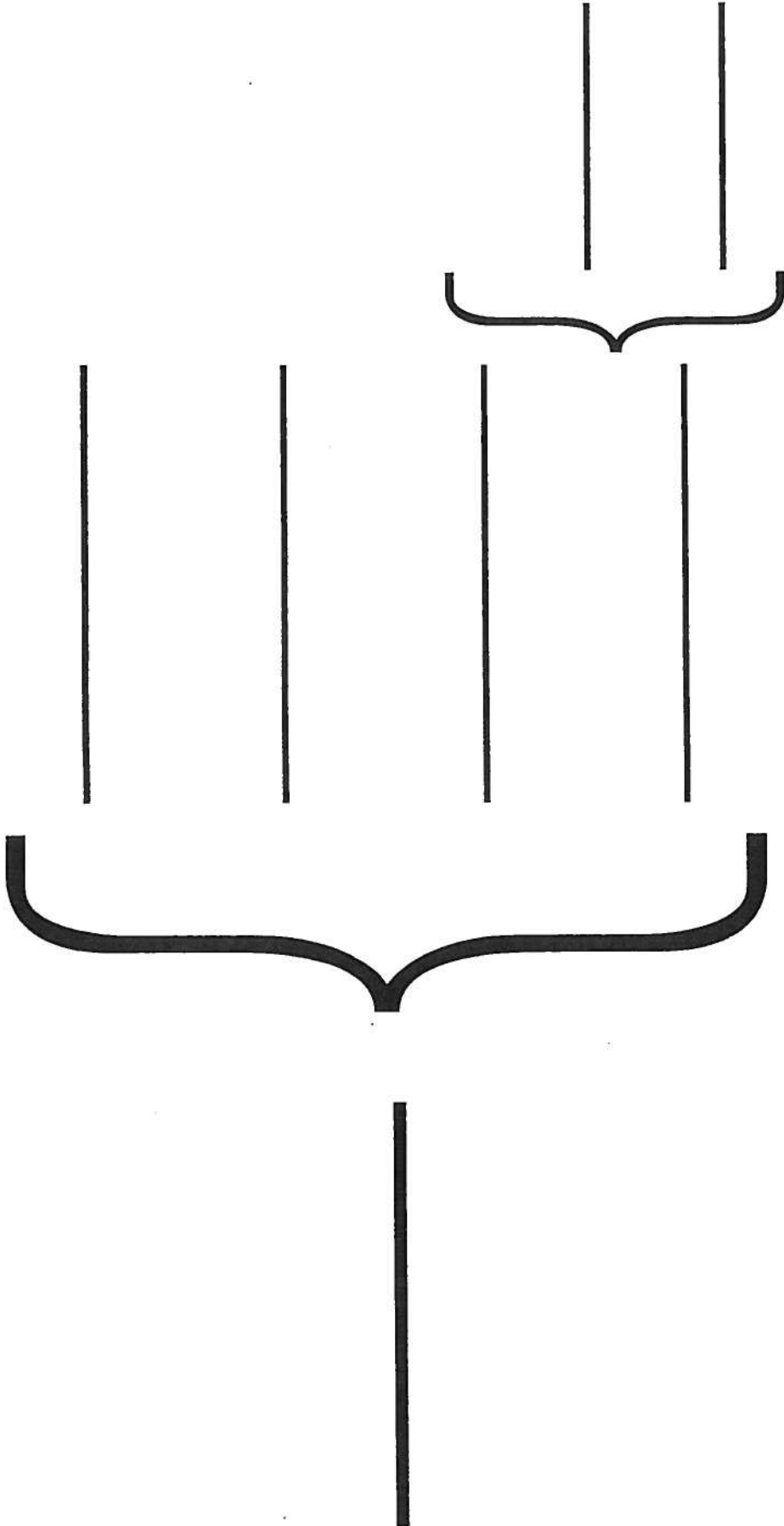

© 2007 Thinking Maps, Inc.

Brace Map

SEQUENCING

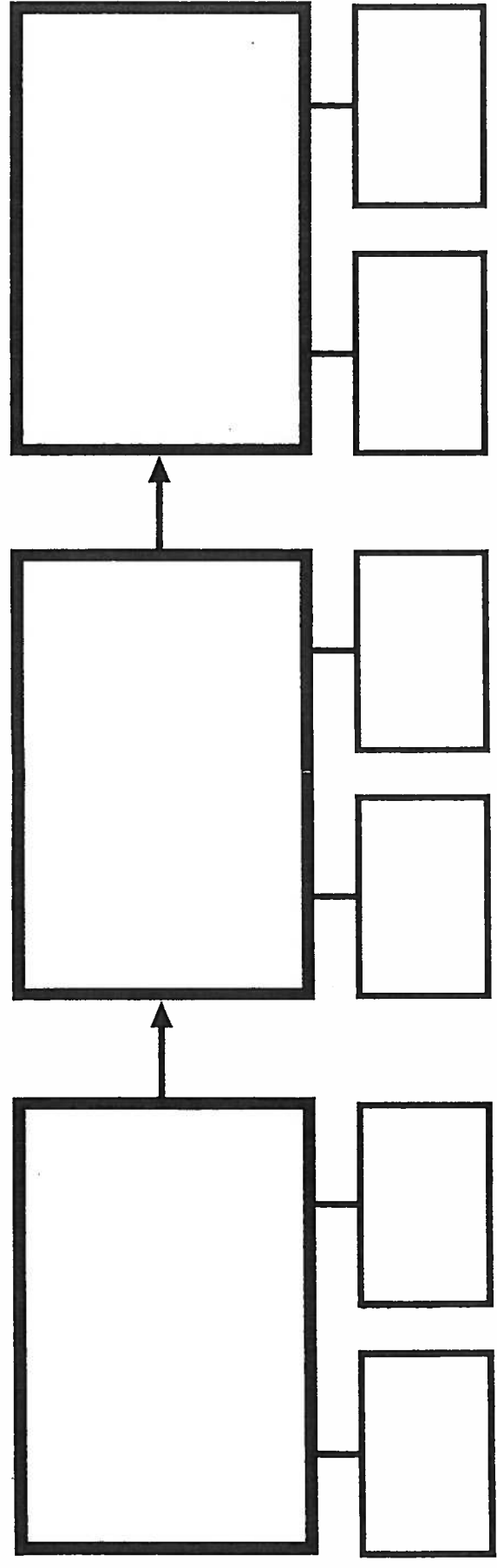

Flow Map

CAUSE & EFFECT

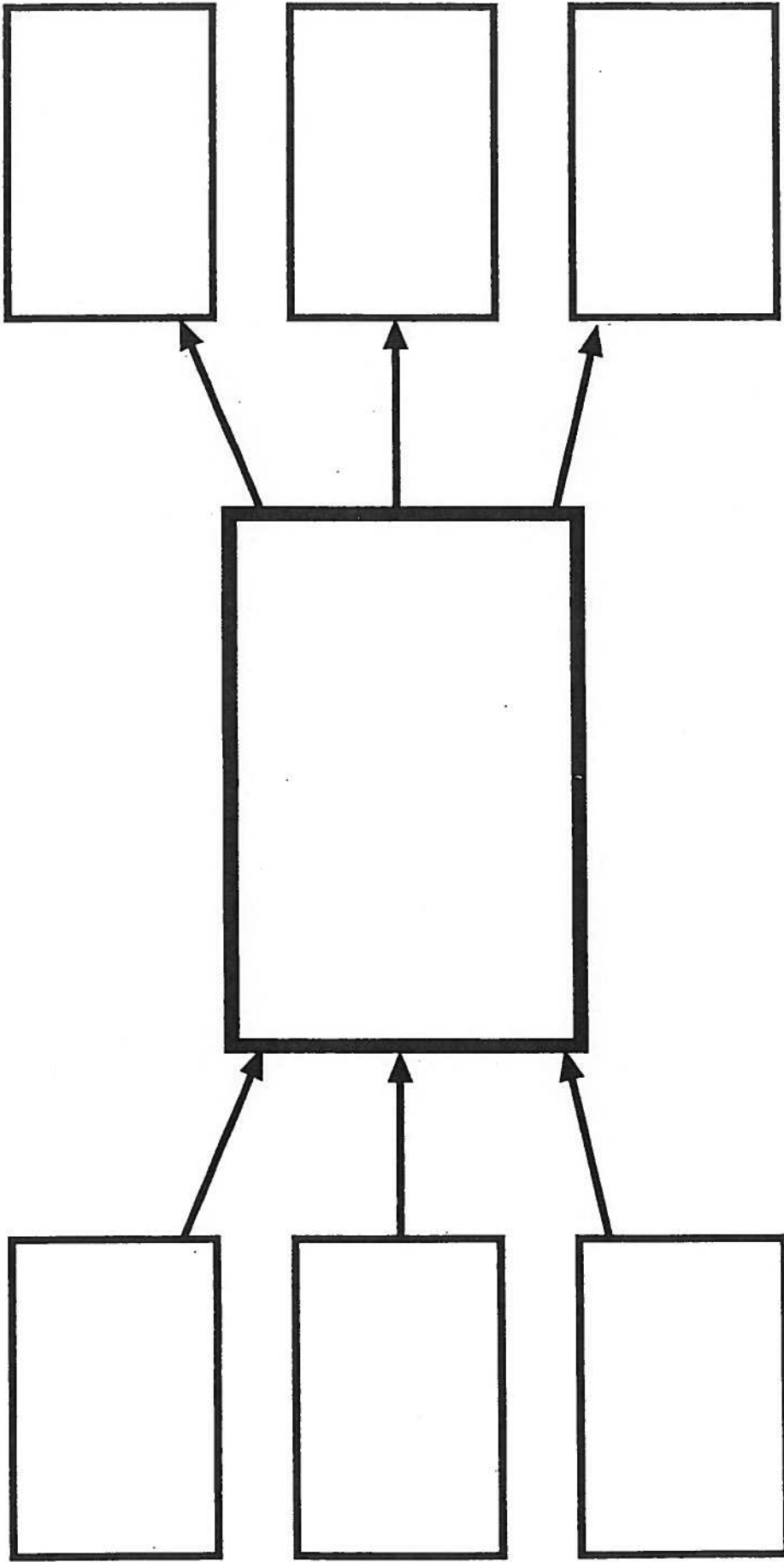

© 2007 Thinking Maps, Inc.

Multi-Flow Map

Thinking Maps
INCORPORATED

SEEING ANALOGIES

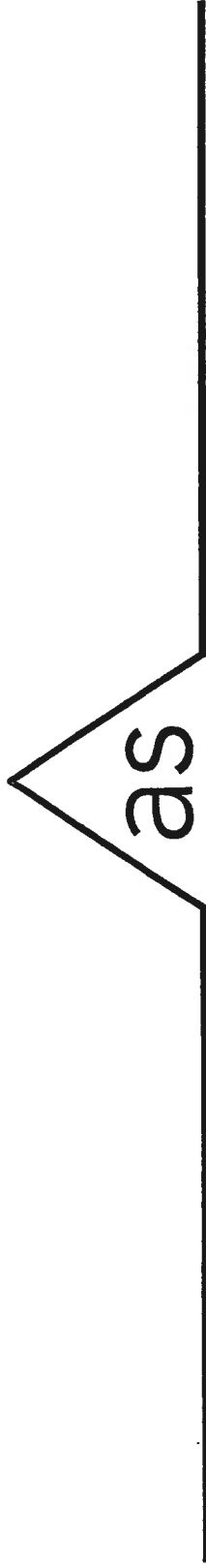

Relating Factor